

Kompact Series

Kompact is a simple solenoid dosing pump, operating with a micro-processor to manage the dosing.

Its external enclosure has an IP65, which guarantees a protection versus splashing water and aggressive environments.



Dosing Mode

The pump head has a manual priming valve.

The flow rate is manually or automatically (by signal input) adjustable from 0 (pump stop) to 100% of the max flow rate. Moreover it is equipped with the low level alarm to stop or not the pump.

Pumps Head

BODY	PVDF
BALL VALVES	Ceramic
SEAT VALVE	FPM/EPDM
DIAPHRAGM	PTFE

The parts in contact with the liquid have been chosen in order to guarantee perfect compatibility with most chemical normally in use.

Long life diaphragm

Tested to give 5 years working life



- The advanced design and manufacturing process allows the diaphragm to have a unique life expectancy
- Made of pure solid PTFE, the diaphragm is compatible with most chemicals
- The diaphragm has been tested over a period of 5 years giving superior results
- Routine diaphragm replacement is no longer a requirement

Wall-mounted

Kompact pump can be fixed on wall by fixing bracket provide with the pump or top of drums by the optional foot fixing bracket.

Kompact Analogue version

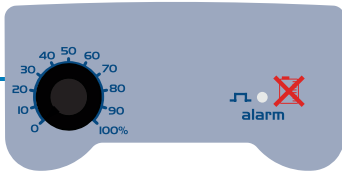

AML Costant dosage

Constant flow rate manually adjustable by control dial on the front panel, two flow rate range:

- 0÷20% with switch in P position,
 - 0÷100% with switch in C position,
- Power-ON led indicator and level control input

Pump Identification

Model

AML Analogue Flow rate by manual control, with level control input

Model	[bar]	Flow rate [L/h]	Stroke capacity [cc/stroke]	Ø Connections IN / OUT [mm]	Frequency max [stroke/min]	Consumption [W]	Weight [Kg]	Carton size (LxWxH)
200	10	3	0.31	4 / 6	160	14	2.5	280×205×180 (mm)
	8	5	0.52					
	2	9	0.93					

Power supply
N AML: 100-240Vac, 50/60Hz

Liquid end material
P Pump head : PVC Balls : Ceramic Diaphragm : PTFE

Installation Kit
E PP

Seals
0 FPM
1 EPDM

Options
000 Standard

AML | 200 | N | P | E | 0 | 000

Solenoid diaphragm pump

Hydraulic diaphragm pump

Mechanical diaphragm pump & plunger pump

Installation

Installation Kit

The pumps are supplied complete with the indispensable accessories for their correct installation as:

Foot filter, Screws, Fixing bracket, Injection valve, 2m PE tube (delivery), 4 m PVC tube (suction), Seal in FPM and EPDM



Wall-mounted bracket



PVC Suction tube



PE Delivery tube



Injection valve (PVC)
(G3/8", G1/2")



Foot valve (PVC)

DIMENSIONAL DRAWINGS

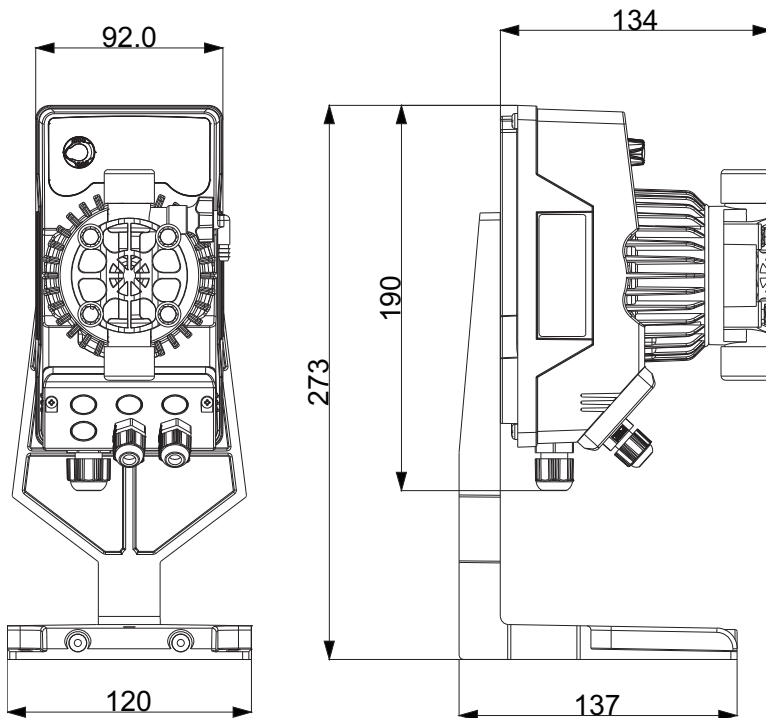

TECHNICAL FEATURES

FLOW RATES	5 l/h @ 8 bar 3 l/h @ 10 bar 9 l/h @ 2 bar 1 l/h @ 7 bar
POWER SUPPLY	AMS:230Vac, 50Hz;AML/AMM/AMM: 100-240Vac,50/60Hz
STROKE RATE	160 strokes/minute
ENCLOSURE	PP protection degree IP65
INSTALLATION KIT	Included